



- **VOLTAGE TEST UNIT 5kV~60kV**
- **TEMPERATURE COEFFICIENT OF 10PPM/°C**
- **0.5%, 0.25%, 0.05%, 0.01% ACCURACY OPTIONAL**
- **METAL SHELL, SIX-SIDED SHIELDING**
- **SMALL SIZE, LIGHT WEIGHT**
- **SHELL HAVE A DEDICATED GROUND TERMINAL**
- **AN INDISPENSABLE TOOL FOR TESTING VOLTAGE**

V6 INTRODUCTION

Wisman's V6 Series is a unit of high-voltage special the value test for the voltage, It is the value used for the test voltage of the DC high voltage power supply, V6 series has a variety of voltage levels optional. Temperature drift 10ppm, Accuracy of 0.5%, 0.25%, 0.05%, 0.01% can option, The use of high voltage power supply is one of the essential test tool for engineers.

V6 TYPICAL APPLICATIONS

DC high voltage power supply testing, long-term high-voltage power system voltage stability analysis.

V6 SELECTION TABLE

MODEL	VOLTAGE LEVEL	MODEL	VOLTAGE LEVEL	MODEL	VOLTAGE LEVEL	MODEL	VOLTAGE LEVEL
V6VL5	5kV	V6VL20	20kV	V6VL35	35kV	V6VL50	50kV
V6VL10	10kV	V6VL25	25kV	V6VL40	40kV	V6VL55	55kV
V6VL15	15kV	V6VL30	30kV	V6VL45	45kV	V6VL60	60kV

V6 SELECTION EXAMPLE

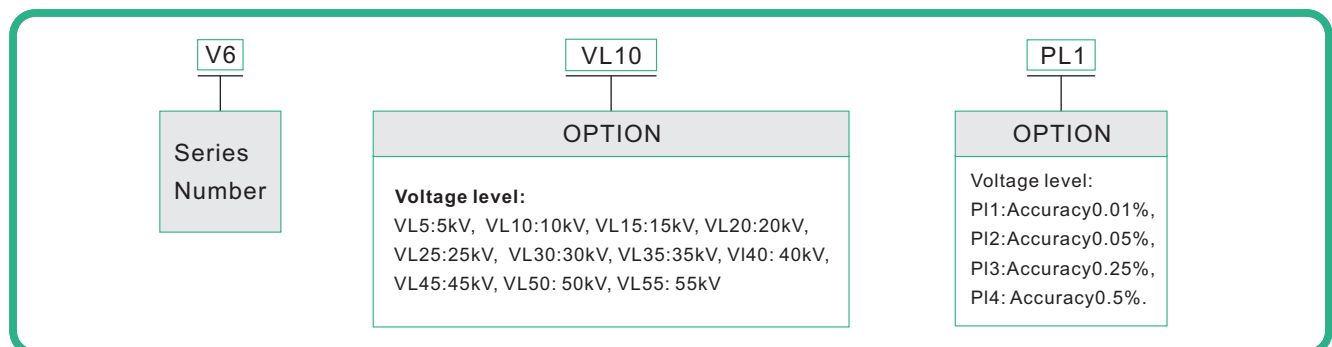



V6 SPECIFICATIONS

PARAMETER	DESCRIBE
HV-IN	Referring to the selection table of voltage levels, You can not input voltage higher than the voltage level of the selected model.
HV-OUT	The exports are mainly for the convenience of customers use when connected to the load, When no load, this can not export terminal.
OUT	This output port needs to use shielded cable connected directly to the input channel of voltage meter, the product label will indicate the maximum voltage amplitude can test, As measured by the magnitude of high voltage power supply is higher than the label indicated value, which means the possibility of damage.
Ground	The device housing must be connected to the ground, if you want to test a small voltage. The unit needs to be connected in the absence of a dedicated ground line noise. Otherwise, the test value fluctuations.
Operation	<ol style="list-style-type: none"> 1. In accordance with the V6 wiring diagram, the line connected, the temperature drift of the voltage meter and the accuracy of the voltage meter shall not be less than the index of the voltage test device. 2. Start test, Slowly raise the voltage of the high voltage power supply, reading voltmeter indication. 3. The end of the test, Wait 5 minutes, Then remove the device, Otherwise there is a risk of electric shock.
Operating Temperature	0°C~+50°C.
Storage Temperature	-40°C~+85°C.
Humidity	20%~85% RH, non-condensing.
Dimensions	3.43" H × 2.56" W × 7.48" D(87mm x 65.00mm x190mm).
Weight	1.6kg.

ACCESSORY

V6 PIN INFORMATION

PIN	DESCRIPTION
1	HV-IN: Input of high voltage power supply
2	HV-OUT: Output of high voltage power supply
3	OUT: Low voltage signal output port connected desktop digital multimeter
4	Ground

V6 CONNECTION DIAGRAM

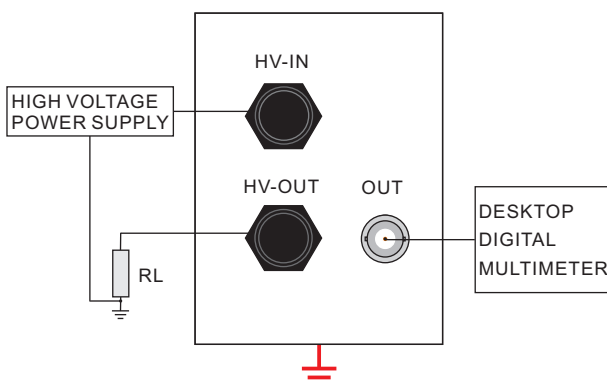

V6 DIMENSIONS

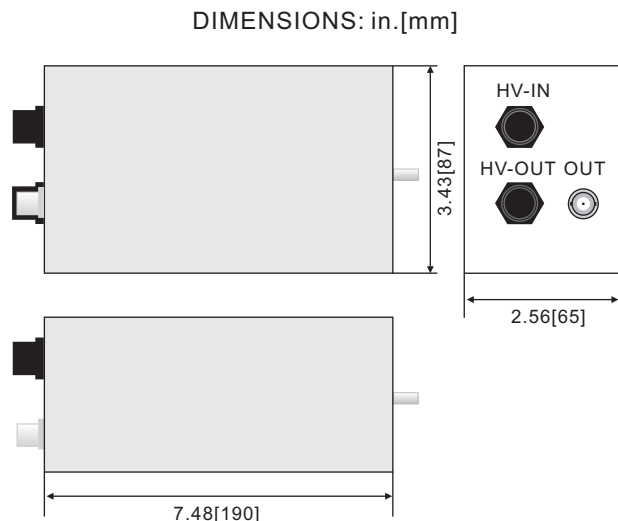

Accessory:
 Shielded coaxial cable: 1m
 High voltage cable: 1m×2 Article
 Ground wire: 1m
 None of the above standard cable, can be customized.