



- DIFFERENTIAL INPUT FOR VOLTAGE PROGRAMM
- OPTIONAL RS-232/RS-485 CONTROL.
- 1KV TO 30KV @ 2W TO 20W MAX.
- HIGH STABILITY & ULTRA LOW RIPPLE & NOISE.
- SIX-SIDED SHIELDED
- ARC PROTECTED
- LOCAL AND REMOTE CONTROL
- OEM CUSTOMIZATION AVAILABLE.

## INTRODUCTION

Wis man's PMS is a six-sided shielded modular high-voltage power supply. It uses a proprietary linear power conversion technology, which has a small size, higher efficiency, and lower ripple. The standard configuration of the PMS series voltage programming given signal uses differential input form, which greatly improves the anti-interference ability to external noise. The PMS series power supply can be measured and controlled internally, externally, and computer. RS-232 and RS-485 interfaces are optional. This series of modules are protected against overcurrent, arcing, short circuit, etc.

## TYPICAL APPLICATIONS

Mass spectrometry, Photomultiplier Tubes, Solid state detectors, Piezoelectric crystal devices, Voltage bias, Ultrasonic transducers, Microchannel plates, Spectra, Scintillation counters, Electron multiplier detectors, Nuclear Instrument, Electrophoresis, DNA sequencing, Counter, Electron beam, Ion beam, Electrostatic chuck, Withstand voltage test, Pulse power supply, Precision lens, Image intensifiers, Semiconductor testing, Capacitor charging, Electrostatic spinning, Electrostatic discharge testing ESD, Life sciences, Medical chemicals, Scientific experiments, Industrial applications.

## PMS SELECTION TABLE

kV	mA	P(W)	MODEL	RIPPLE(mVp-p)	kV	mA	P(W)	MODEL	RIPPLE(mVp-p)	kV	mA	P(W)	MODEL	RIPPLE(mVp-p)
1	5.0	5	PMS1*5	10	3	1.67	5	PMS3*5	25	15	0.33	5	PMS15*5	100
	10.0	10	PMS1*10	10		3.33	10	PMS3*10	25		0.67	10	PMS15*10	100
	20.0	20	PMS1*20	25		6.67	20	PMS3*20	75		1.33	20	PMS15*20	370
2	2.5	5	PMS2*5	20	5	1.0	5	PMS5*5	30	20	0.25	5	PMS20*5	150
	5.0	10	PMS2*10	20		2.0	10	PMS5*10	30		0.5	10	PMS20*10	150
	10.0	20	PMS2*20	50		4.0	20	PMS5*20	120		1.0	20	PMS20*20	500
2.5	2.0	5	PMS2.5*5	25	10	0.5	5	PMS10*5	50	30	0.17	5	PMS30*5	250
	4.0	10	PMS2.5*10	25		1.0	10	PMS10*10	50		0.33	10	PMS30*10	250
	8.0	20	PMS2.5*20	60		2.0	20	PMS10*20	250		0.67	20	PMS30*20	1000

## PMS SELECTION EXAMPLE

PMS	30	*	20	VIP	10	VIM	10	TC25	LCX	M1
Series Name	MAX. Output Voltage (KV)	Output Polarity P: Positive N: Negative	MAX. Output Power (W)	Option VP: Voltage Program IP: Current Program VIP: Voltage and Current Program	Option 10:0 ~+10Vdc Programming =0 to Max. Output 5:0 ~+5Vdc Programming =0 to Max. Output	Option VM: Voltage Monitor IM: Current Monitor VIM: Voltage and Current Monitor	Option 10:0 ~+10Vdc Monitor=0 to Max. Output 5:0 ~+5Vdc Monitor=0 to Max. Output	Option TC25: 25ppm/C TC10: 10ppm/C	Option shield cable Xm (X option)	Option M1, M2, M3 (SEE NEXT PAGE)



**SPECIFICATIONS**

PARAMETER	DESCRIBE
Input Voltage	+24Vdc±2Vdc@1.5 amp maximum.
Output Voltage	1kV~30kV,20W MAX.
Stability	After 0.5 hour warm-up,per hour≤0.007%, per 8 hours≤0.01%,per 8 hours≤0.05%.
Temperature Coefficient	< 25ppm/°C , option 10ppm/°C(TC10).
Ripple	See “PMS SELECTION TABLE” .
Reference Voltage	+10Vdc ±1%.
Output Voltage Accuracy	±2%, When Vp-in=+10.00Vdc.
Voltage/Current Monitor	0~+10Vdc corresponds to 0 to maximum output,Zout=10kΩ.
Voltage Local Programming	By internal potentiometer ,0~+10Vdc for 0 to maximum output.
Voltage Remote Programming	By external 20kΩ potentiometer or external voltage control (0~+10Vdc,Zin=10MΩ,Accuracy:±1%).
Voltage Program Differential Amplifier Input Positive	0~+10Vdc differential between pin 7 and pin 9 = 0 ~ 100% of rated output, diode clamped to ground, Zin =38kΩ..
Voltage Program Differential Amplifier Input Negative	0~+10Vdc differential between pin 7 and pin 9 = 0 ~ 100% of rated output, diode clamped to ground, Zin =38kΩ.
Voltage Program Differential Amplifier Output	0~+10Vdc=0 to 100% Rated Output, Zout=10kΩ.
Input Current Programming	Standard: Internally connected to provide 110% fixed current limit , IP option: 0 ~ +10Vdc=0 to 100% Rated Output, Zin=1MΩ.
Voltage Load Regulation	Load:0.001% of rated output voltage for full load change.
Voltage Line Regulation	Line: 0.001% of rated output voltage over specified input voltage.
Operating Temperature	0°C ~ 50°C.
Storage Temperature	-35°C ~ 85°C.
Humidity	20% ~ 85% Rh, non-condensing.
Dimensions	See next page.
Weight	1kV~3kV: 280g; 5kV~10kV:420g;10kV~20kV: 650g; 20kV~30kV: 850g;.

MODULES

**15 PIN CONNECTION DIAGRAM**

**M1: Differential input for voltage program**

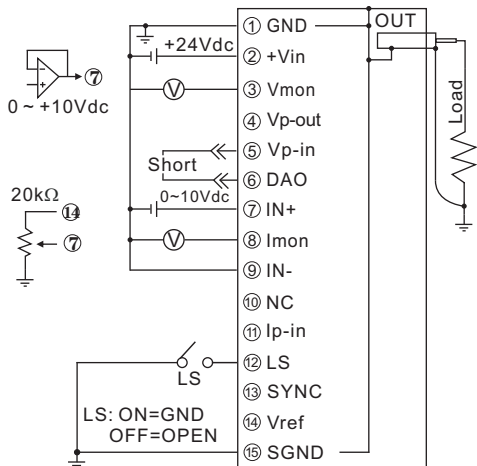

**M2: RS-485**

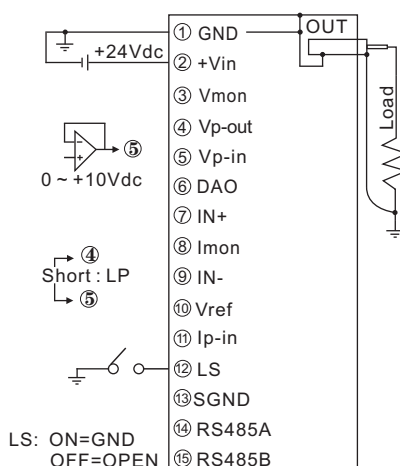

**M3: RS-232**

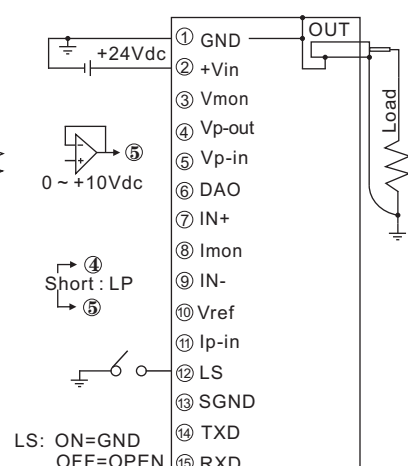

## DIMENSIONS

DIMENSIONS:in.[mm]

FRONT VIEW

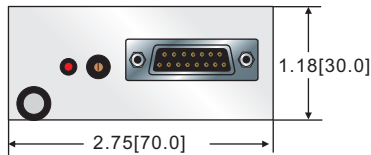

FRONT VIEW

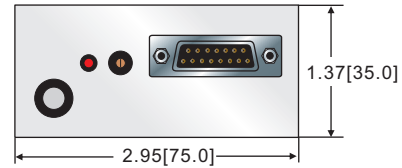

BOTTOM VIEW

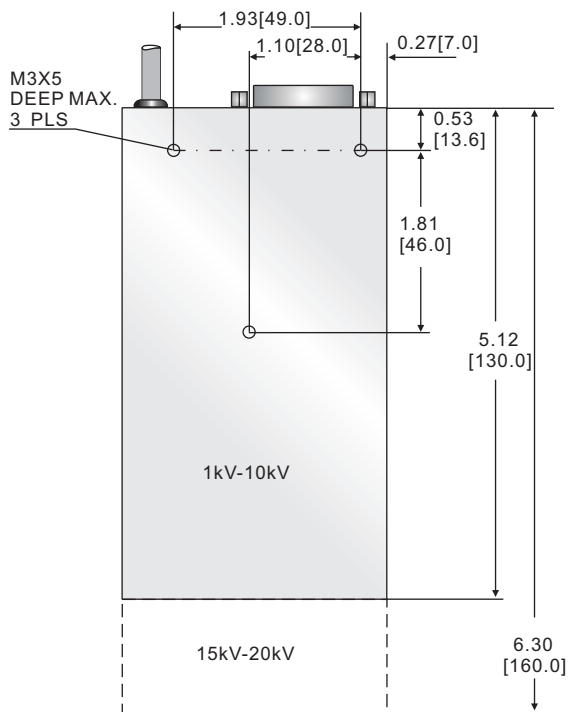

BOTTOM VIEW

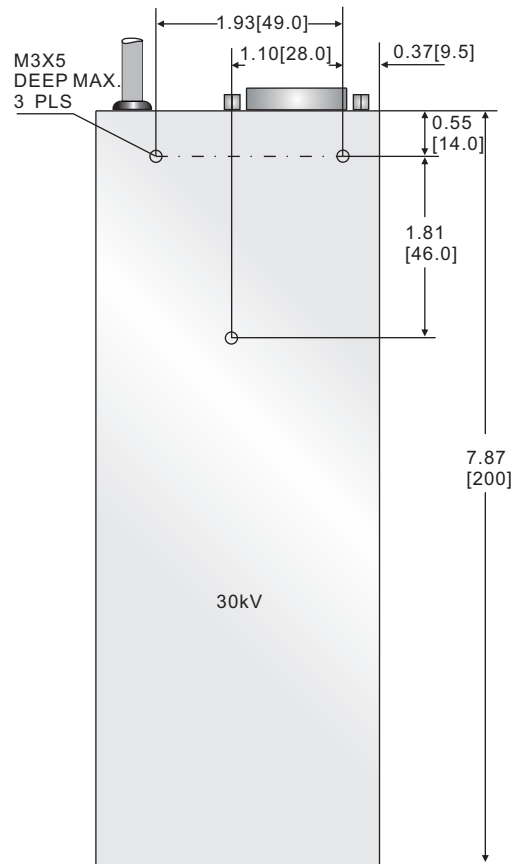

SIDE VIEW

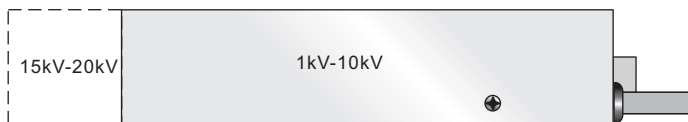

SIDE VIEW

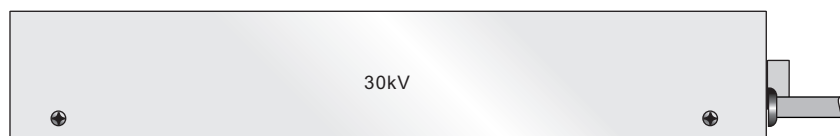

C6  
MODULES