



- OPTIONAL USB2.0,RS-232 OR RS-485 IS AVAILABLE
- 100kV,200 WATT MAX
- ADJUSTABLE INTEGRATED FILAMENT SUPPLY
- OVER VOLTAGE, ARC& SHORT CIRCUIT PROTECTION
- VOLTAGE & CURRENT PROGRAMMING
- LOCAL AND REMOTE CONTROL
- SAFETY INTERLOCK
- OEM CUSTOMIZATION AVAILABLE

INTRODUCTION

Wisman's XFL series is high stable, low ripple compact x-ray generator specialized for all kinds of x-ray tubes from different manufacturers. XFL series can output negative voltage and provide floating filament voltage. Wisman's XFL series can realize local, remote and computer control, with option of RS232,RS485,USB2.0 and ET interface, XFL x-ray generator is with the function of overvoltage, overcurrent, arc and safety interlock protection .

TYPICAL APPLICATIONS

X-Ray Fluorescence, X-Ray Diffraction, Plating Measurement , Crystal Inspection, Diamond Inspection, Mineral Analysis, Plastics Sorting. X-ray tubes ,Capacitor Charging, Industrial applications, Electronic component aging, Insulation Test, Electrophoresis, Electrostatics Applications, Laser, Science, Laboratory Applications. ESD, Sulfur-detector,X-ray imaging, Non-destructive testing, Portable X-ray machine, Rohs detector, Life Science, Precious metal detector, Industrial application.

XFL SELECTION TABLE

kV	mA	P(W)	MODEL	kV	mA	P(W)	MODEL	kV	mA	P(W)	MODEL
20	3.75	75	XFL20N75	50	1.5	75	XFL50N75	80	0.94	75	XFL80N75
	4.5	90	XFL20N90		1.8	90	XFL50N90		1.13	90	XFL80N90
	5.0	100	XFL20N100		2	100	XFL50N100		1.25	100	XFL80N100
	6.0	120	XFL20N120		2.4	120	XFL50N120		1.5	120	XFL80N120
	7.5	150	XFL20N150		3	150	XFL50N150		1.88	150	XFL80N150
	10.0	200	XFL20N200		4	200	XFL50N200		2.5	200	XFL80N200
30	2.5	75	XFL30N75	60	1.25	75	XFL60N75	90	0.83	75	XFL90N75
	3	90	XFL30N90		1.5	90	XFL60N90		1	90	XFL90N90
	3.33	100	XFL30N100		1.67	100	XFL60N100		1.11	100	XFL90N100
	4	120	XFL30N120		2	120	XFL60N120		1.33	120	XFL90N120
	5	150	XFL30N150		2.5	150	XFL60N150		1.67	150	XFL90N150
	6.67	200	XFL30N200		3.33	200	XFL60N200		2.22	200	XFL90N200
40	1.88	75	XFL40N75	70	1.07	75	XFL70N75	100	0.75	75	XFL100N75
	2.25	90	XFL40N90		1.29	90	XFL70N90		0.9	90	XFL100N90
	2.5	100	XFL40N100		1.43	100	XFL70N100		1	100	XFL100N100
	3	120	XFL40N120		1.71	120	XFL70N120		1.2	120	XFL100N120
	3.76	150	XFL40N150		2.14	150	XFL70N150		1.5	150	XFL100N150
	5	200	XFL40N200		2.86	200	XFL70N200		2	200	XFL100N200

XFL SELECTION EXAMPLE

XFL	100	N	200	VIP	10	VIM	10	TR	AX	48
Series Number	Maximum Output Voltage (kV)	Output Polarity N: Negative	Maximum Output Power (W)	Option Voltage Program Current Program Voltage/Current Program	Option 0~+10Vdc =0 to full scale	Option Voltage Monitor Current Monitor Voltage/Current Monitor	Option 0~+10Vdc =0 to full scale	Option USB2.0 TR:RS232 AB:RS485	Option X=0,1,2,3,5,8,N arc(N=ARC,does not shutdown. 0= No ARC)	Input Voltage +48Vdc±10%



SPECIFICATIONS

ISO9001:2015

Page 2 of 4

D X-RAY GENERATOR

PARAMETER		DESCRIBE		
Input Voltage		+48Vdc±10%, 6.25A maximum.		
Output Voltage		20kV ~100kV, 75W~200W		
Stability		0.01% per hour 0.02% per 8 hour after 1/2 hour warm-up.		
Temperature Coefficient		≤25ppm/°C.		
Ripple		0.1% p-p of output voltage.		
Voltage/Current Monitor		0 ~ +10Vdc proportional from 0 to rated output. Accuracy ±1%.		
Local Voltage Programming		Internal multi-turn potentiometer to set voltage from 0 to full output voltage.		
Local Current Programming		Internal potentiometer to set beam current between 0 to full output current.		
Remote Voltage Programming		0 ~ +10Vdc proportional from 0 to full output voltage, Zin=10MW.		
Remote Current Programming		0 ~ +10Vdc proportional from 0 to full output current, Zin=10MW.		
Voltage Load Regulation		Load: 0.01% of output voltage no load to full load.		
Voltage Line Regulation		Line: ±0.01% for ±10% change in input voltage.		
Current Load Regulation		Load: 0.01% of output current from 0 to rated voltage.		
Current Line Regulation		Line: ±0.01% for ±10% change in input voltage.		
AC Filament Supply		Current: 0.3~3.5A, adjustable Voltage: 0~5.5Vdc		
Operating Temperature		0°C~+50°C.		
Storage Temperature		-40°C~+85°C.		
Cooling		Free convection for P≤100W, Fan (30CFM) assisted for P>120W, except 40kV.		
Humidity		20%~85% RH, non-condensing.		
Dimensions	20kV~40kV	4.72" H x 4.72" W x 6.54" D (120mm x 120mm x166mm).	Weight	3.0kg
	40kV~70kV	5.51" H x 3.94" W x 9.06" D (140mm x 100mm x230mm).		3.05kg
	70kV~100kV	6.10" H x 7.48" W x15.94" D (155mm x 190mm x405mm).		3.5kg

**XFLPOWER INPUT/
FILAMENT OUTPUT CONNECTOR**

PIN	SIGNAL	
1	Gnd	Power Ground
2	+48Vdc Input	Power Input

ANALOG INTERFACE CONNECTION

I/O	SIGNAL	PARAMETER
1	Ground	Ground
2	Voltage Monitor	0~+10Vdc=0 to full scale, Zout=10kΩ
3	Current Monitor	0~+10Vdc=0 to full scale, Zout=10kΩ
4	Interlock Output	Alternate Interlock Configurations
5	+10Vdc Reference	+10Vdc @ 1mA, maximum
6	Filament Monitor	1Vdc=1A, Zout=11kΩ
7	Voltage Program Input	0 ~ +10Vdc = 0 to full scale, Zin=10MΩ
8	Local Voltage Program	0 ~ +10Vdc, screwdriver adjust
9	Power Supply Fault	0=Fault
10	Reset	Reset=0
11	Interlock output	Optional Interlock Configuration+15Vdc
12	Interlock coil	Connect to pin 12 to HV enable supply
13	Local Current Program	10 turn pot, screwdriver adjust
14	Filament Preheat Setpoint	0 ~ +10Vdc=0 to full scale, Zin=10MΩ
15	Ground	Ground

**XFL VOLTAGE
OUTPUT CONNECTOR**

PIN	SIGNAL	
1	C(common)	Voltage Output
2	S (small)	Voltage Output
3	L (large)	Faliment Output
4	G (grid)	Faliment Output

RS-232/RS-485 DIGITAL INTERFACE ^D

SIGNAL		SIGNAL	
1	N/C	6	N/C
2	TXD/Transmit Data	7	RS-485B
3	RXD/Receive Data	8	N/C
4	N/C	9	RS-485A
5	SGND		

USB DIGITAL INTERFACE ^D

USB	SIGNAL	USB	SIGNAL	
1	VBUS	3	D+	Data+
2	D-	4	GND	USB Ground

XFL LED INDICATORS ^D

LED	SIGNAL	
1	ARC	Arc fault occurs
2	OT	Over temperature occurs
3	OC	Over current occurs
4	INTLK	Interlock Control
5	UC	Over voltage occurs
6	UV	Low voltage occurs
7	HV	HV ON

DIMENSIONS

DIMENSIONS in.[mm]

20kV~40kV:

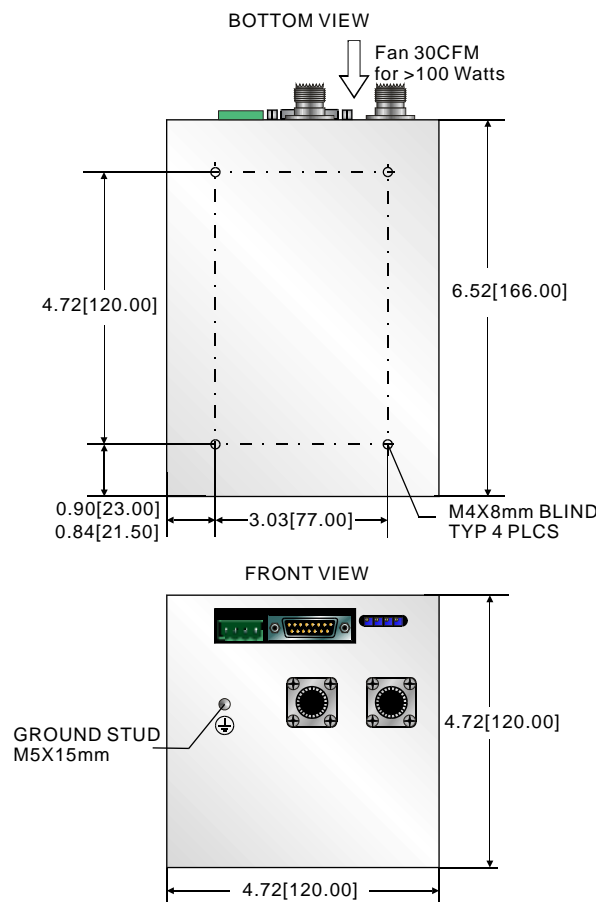



40~70kV(USB2.0/RS232/RS485):

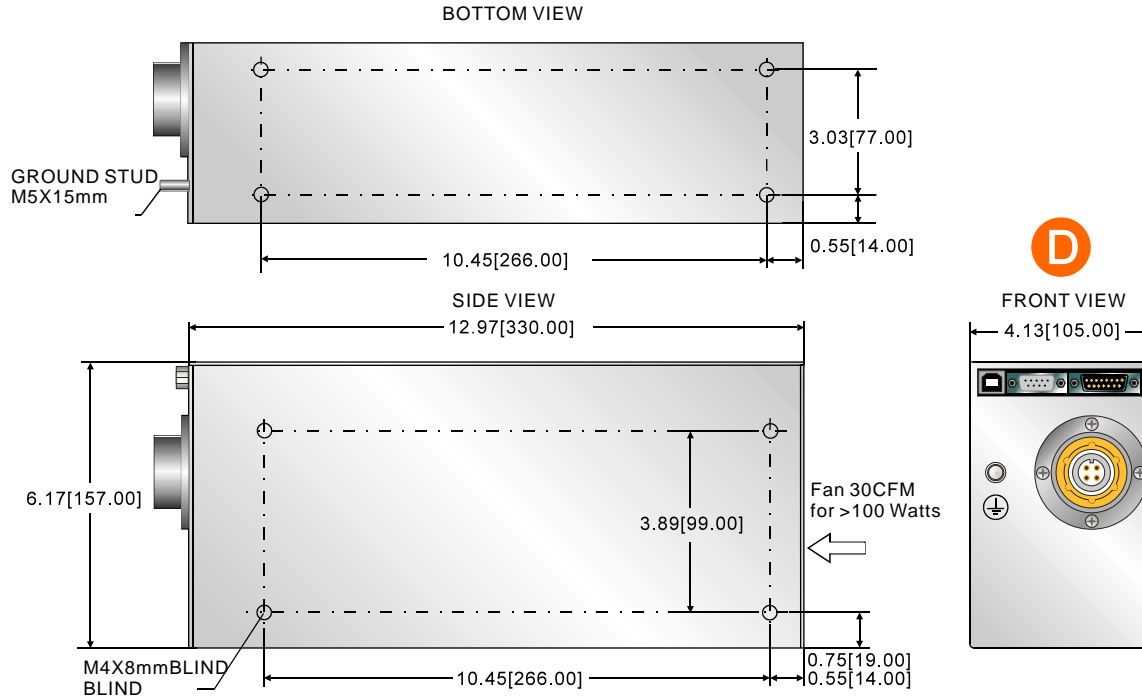

70~100kV(USB2.0/RS232/RS485):

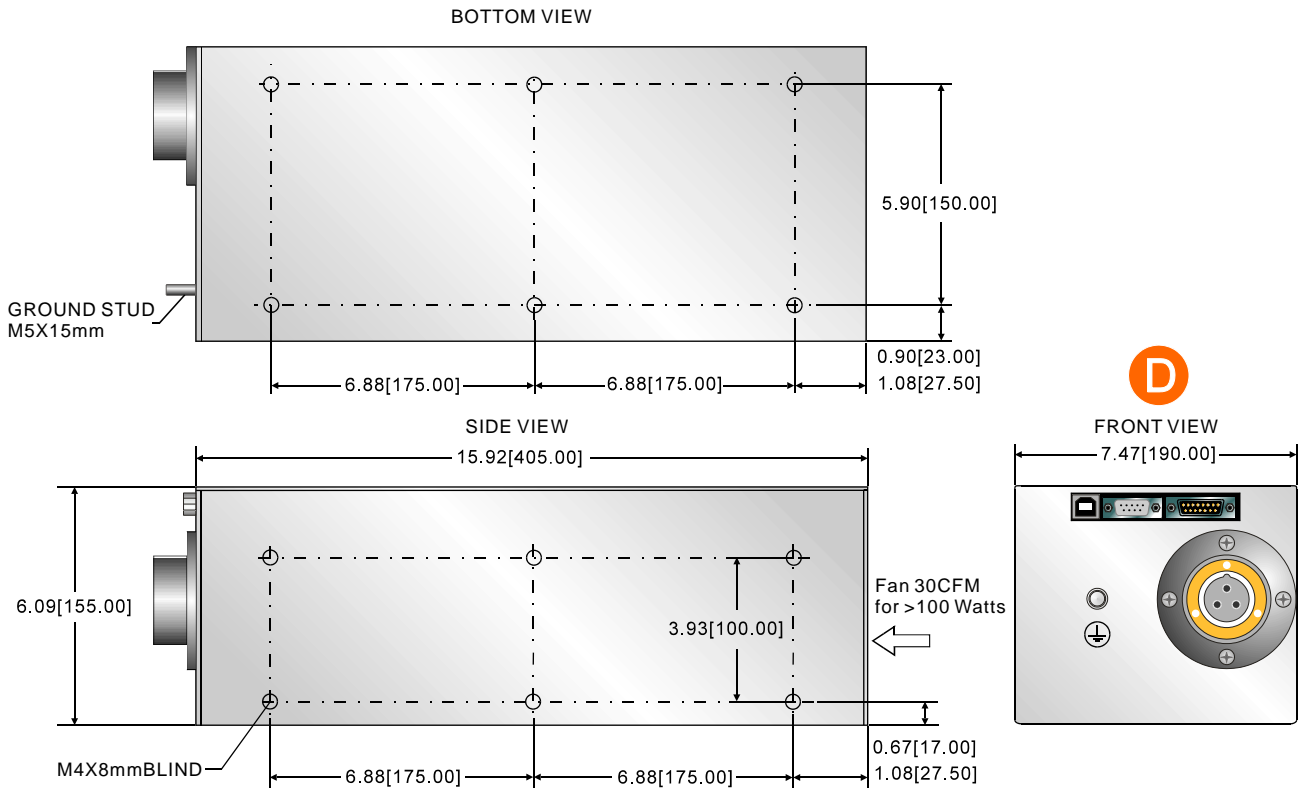

D X-RAY GENERATOR