

- OUTPUT FROM 1kV~70kV
- INPUT 86Vac-265Vac
- POWER FACTOR CORRECTED FRONT END
- OPTIONAL RS-232 OR RS-422 IS AVAILABLE
- OVERVOLTAGE & SHORT CIRCUIT PROTECTION
- LOCAL AND REMOTE CONTROL
- SAFETY INTERLOCK
- OEM CUSTOMIZATION AVAILABLE



INTRODUCTION

Wisman MRC series are high-stability with positive or negative high voltage output. The MRC series can be accurately measured and controlled internally, externally, or controlled by a computer. The MRC series has the protection function includes overvoltage, overcurrent, arcing, and safety interlock.

TYPICAL APPLICATIONS

High voltage experimentation, Electron Beam and Ion Beam, ESD, Electrospinning, Electrophoresis, Provides power to the pulse power, Capacitor Charging, Semiconductor Testing, DNA sequencing, High voltage bias, Medical, chemical Applications, Science, Laboratory Applications, Industrial applications.

MRC SELECTION TABLE

kV	mA	P(W)	MODEL	kV	mA	P(W)	MODEL
1	120	120	MRC1*120	30	4	120	MRC30*120
3	40	120	MRC3*120	40	3	120	MRC40*120
5	24	120	MRC5*120	50	2.4	120	MRC50*120
10	12	120	MRC10*120	60	2	120	MRC60*120
15	8	120	MRC15*120	70	1.7	120	MRC70*120
20	6	120	MRC20*120				

MRC SELECTION EXAMPLE

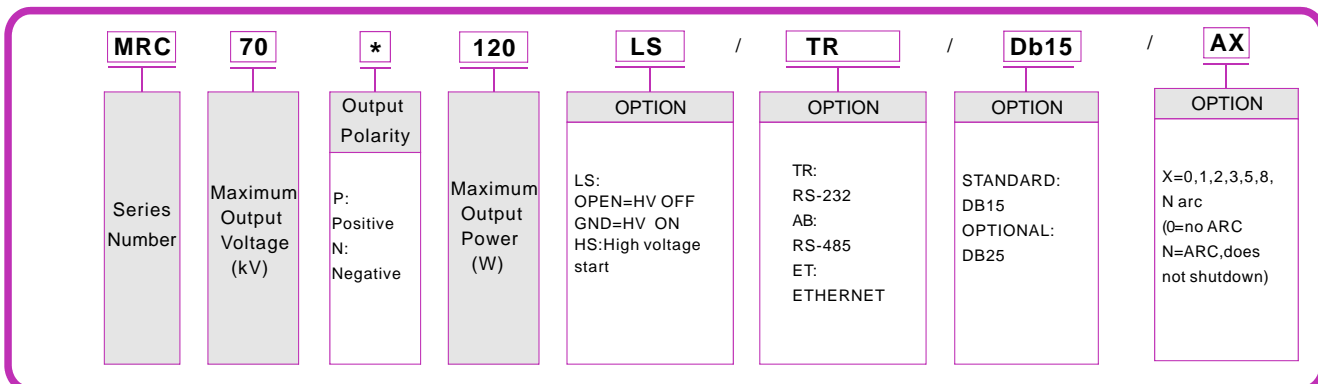



SPECIFICATIONS

PARAMETER	DESCRIBE
Input	86Vac~265Vac,47Hz~63Hz.
Output	1kV, 3kV, 6kV, 10kV, 20kV, 30kV, 40kV, 50kV, 60kV, 70kV Maximum output Voltage option.120W Maximum output power option.
Stability	0.01% per hours after 1/2 hour warm-up,0.02%/8 hours.
Temperature Coefficient	≤25ppm/°C.
Ripple	≤1% rms (>20kHz),0.1% rms (≤20kHz).
Voltage/Current Monitor	0~+10Vdc corresponds to 0 to maximum output, Zout=4.99kW, accuracy:±1%.
Voltage Local Programming	Internal potentiometer to set voltage from 0 to maximum output voltage.
Voltage Remote Programming	0~+10Vdc proportional from 0 to maximum output voltage, Zin=10MW.
Current Local Programming	Internal potentiometer to set current from 0 to maximum output current.
Current Remote Programming	0~+10Vdc proportional from 0 to maximum output current, Zin=10MW.
Voltage Load Regulation	0.01% (no load to full load change).
Voltage Line Regulation	±0.01% (input voltage line change±10%).
Current Load Regulation	0.01% (no load to full load change).
Current Line Regulation	±0.01% (input voltage line change 30%-100%).
Operating Temperature	0°C~+50°C.
Storage Temperature	-40°C~+85°C.
Humidity	20%~85% RH, non-condensing.
Dimensions 1kV~50kV	9.06" H x 5.00" W x 3.62" D(230.00mm x 127.00mm x92.00mm).
Dimensions 60kV~70kV	11.02" H x 5.00" W x 3.62" D(280.00mm x 127.00mm x92.00mm).
Weight	1kV~50kV: 3.5kg. 60kV~70kV: 4.5kg.

MRC ANALOG INTERFACE

I/O	PARAMETER	I/O	PARAMETER
1	SGND	14	No Used
2	Low Voltage Enable	15	No Used
3	No Used	16	No Used
4	Voltage Monitor	17	No Used
5	SGND	18	SGND
6	Voltage Program Input	19	INTLK-RT
7	No Used	20	SGND
8	SGND	21	No Used
9	INTLK	22	No Used
10	Current Monitor	23	+10 Vdc Reference
11	No Used	24	+10 Vdc Reference
12	+10 Vdc Reference	25	+10 Vdc Reference
13	Current Program Input		

RS-232/RS-485 DIGITAL INTERFACE ^D

SIGNAL		SIGNAL	
1	N/C	6	N/C
2	TXD/Transmit Data	7	RB-/RB- Receive
3	RXD/Receive Data	8	NC
4	N/C	9	TA+/TA+ Transmit
5	SGND		

MRC ANALOG INTERFACE ^D

I/O	PARAMETER	I/O	PARAMETER
1	Current Program Input	9	Power Supply Fault
2	Voltage Program Input	10	+10 Vdc Reference
3	Low Voltage Enable	11	SGND
4	Current Monitor	12	No Used
5	Interlock Output	13	No Used
6	Interlock	14	No Used
7	Voltage Monitor	15	Voltage Current Output
8	Voltage Program Output		

ETHERNET DIGITAL INTERFACE ^D

SIGNAL		
1	RX+	Receive Data+
2	RX-	Receive Data-
3	TX+	Transmit Data+
4	N/C	N/C
5	N/C	N/C
6	TX-	Transmit Data-
7	N/C	N/C
8	N/C	N/C

DIMENSIONS

DIMENSIONS: in.[mm]

SIDE VIEW

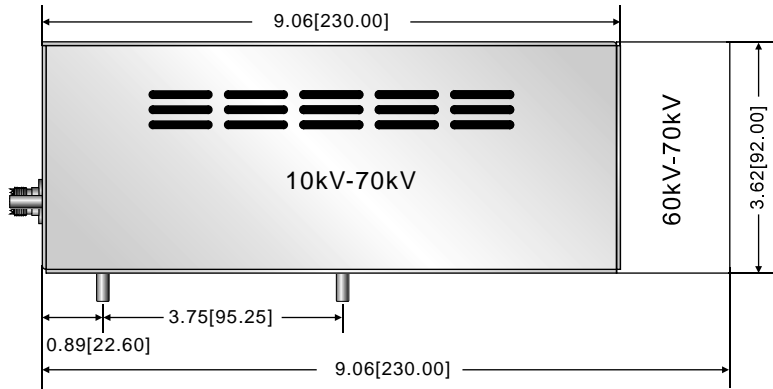

TOP VIEW

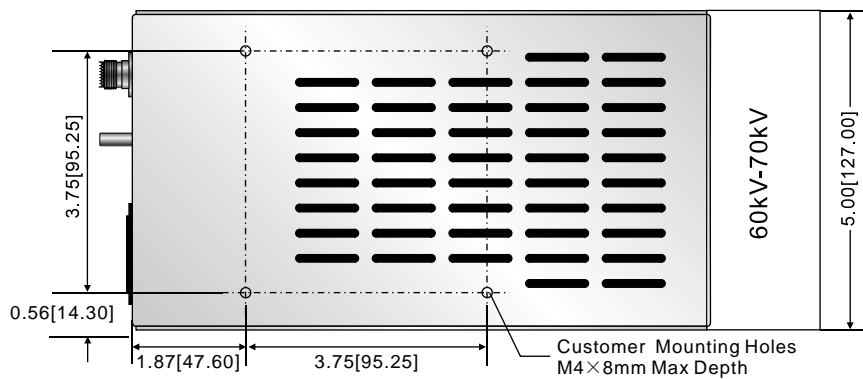

FRONT VIEW

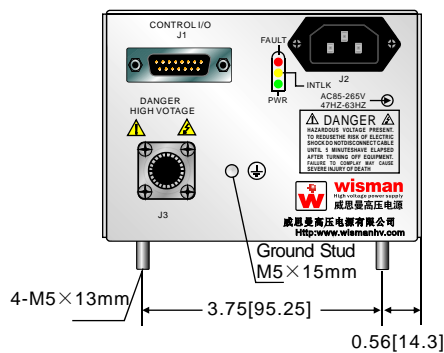

STANDARD

FRONT VIEW

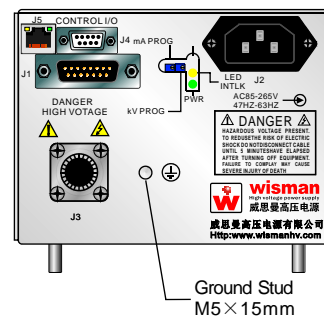

OPTION