

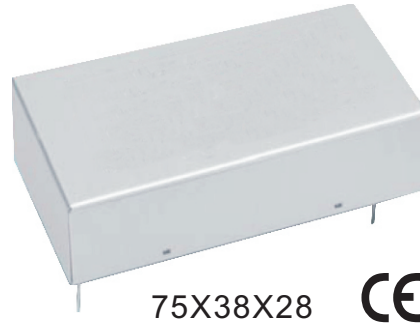

- **ULTRA COMPACT, HIGH POWER**
- **LOW RIPPLE, HIGH STABILITY**
- **HIGH RELIABILITY**
- **EXTERNAL OR INTERNAL POTENTIOMETER FOR VOLTAGE CONTROL**
- **OUTPUT POWER : 6W~30W**
- **CUSTOMIZATION AVAILABLE**



75X38X28



**A**  
**MICRO-MODULES**

## INTRODUCTION

Wisman's MU series of printed circuit board mounted high-voltage modules is currently ahead of the market in terms of product appearance and power density. These SMT-based high-voltage power modules have superior performance and high reliability. MU series is the ideal choice for OEM.

## TYPICAL APPLICATIONS

Mass spectrometry photomultiplier tubes (PMT), solid state detectors, Piezo crystal devices, ultrasonic transducers, microchannel plates (MCP), spectroscopy, scintillation counters, electron multiplier detectors, nuclear Instruments, electrophoresis, semiconductor testing, DNA sequencing, radiation counter, electron and ion beams, electrostatic chuck, high voltage, bias hipot testing, precision lenses, image intensifiers, semiconductor testing, chemical applications, laboratory applications, industrial application supplies.

## MU SELECTION TABLE

kV	mA	P(W)	MODEL	Rippe(%p-p)	kV	mA	P(W)	MODEL	Rippe(%p-p)	kV	mA	P(W)	MODEL	Rippe(%p-p)	kV	mA	P(W)	MODEL	Rippe(%p-p)
0.05	120	6	MU0.05*6	0.04	0.2	30	6	MU0.2*6	0.04	1	6.0	6	MU1*6	0.015	4	1.5	6	MU4*6	0.02
	200	10	MU0.05*10	0.04		50	10	MU0.2*10	0.04		10.0	10	MU1*10	0.045		2.5	10	MU4*10	0.045
	400	20	MU0.05*20	0.08		100	20	MU0.2*20	0.08		20.0	20	MU1*20	0.045		5.0	20	MU4*20	0.045
	600	30	MU0.05*30	0.08		150	30	MU0.2*30	0.08		30.0	30	MU1*30	0.07		7.5	30	MU4*30	0.065
0.1	60	6	MU0.1*6	0.04	0.25	24	6	MU0.25*6	0.04	2	3.0	6	MU2*6	0.015	5	1.2	6	MU5*6	0.025
	100	10	MU0.1*10	0.04		40	10	MU0.25*10	0.04		5.0	10	MU2*10	0.04		2.0	10	MU5*10	0.02
	200	20	MU0.1*20	0.08		80	20	MU0.25*20	0.08		10.0	20	MU2*20	0.04		4.0	20	MU5*20	0.02
	300	30	MU0.1*30	0.08		120	30	MU0.25*30	0.08		15.0	30	MU2*30	0.015		6.0	30	MU5*30	0.04
0.15	40	6	MU0.15*6	0.04	0.5	12	6	MU0.5*6	0.04	3	3.0	6	MU3*6	0.02	6	1.0	6	MU6*6	0.025
	66.7	10	MU0.15*10	0.04		20	10	MU0.5*10	0.04		3.3	10	MU3*10	0.045		1.67	10	MU6*10	0.02
	133.3	20	MU0.15*20	0.08		40	20	MU0.5*20	0.08		6.7	20	MU3*20	0.045		3.4	20	MU6*20	0.02
	200	30	MU0.15*30	0.08		60	30	MU0.5*30	0.08		10	30	MU3*30	0.065		5.0	30	MU6*30	0.04

## MU SELECTION EXAMPLE

MU	6	*	30	VIP	5	VIM	5	M1	/	24
Series number	Maximum Output Voltage (kV)	Power Polarity P: Positive Polarity N: Negative Polarity	Maximum Output Power(W)	OPTION VP: Voltage Programming IP: Current Programming VIP: Voltage and current Programming	OPTION 10:0~+10Vdc= 0 to maximum output 5:0~+5Vdc= 0 to maximum output	OPTION VM: Voltage Monitor IM: Current Monitor VIM: Voltage and Current Monitor	OPTION 10:0~+10Vdc= 0 to maximum output 5:0~+5Vdc= 0 to maximum output	OPTION M1: M1 option M2: M2 option M3: M3 option	OPTION 12:+12Vdcfor6W 24:+24Vdcfor 10W20W and30W	

## MU SPECIFICATIONS

PARAMETER	DESCRIBE
Input Voltage/current	+24dc $\pm 2\%$ Vdc input current $\leq 1.7A$ . 0W~6W optional +12Vdc $\pm 2\%$ input, input power $\leq 0.7A$ .
Output Voltage	50V~6kV, 6W~30W output power available.
Temperature Coefficient	$\leq 15ppm/^{\circ}C$ .
Stability	$< 0.01\%/8hr$ after a 30 minute warm-up period.
Accuracy	$\pm 1\%$
Ripple	See MU selection tabale.
Voltage/Current Monitor	0 ~ +5Vdc corresponds to 0 to 100% output voltage, $Z_{out} = 1k\Omega$ .
Voltage/Current Programming	0~ +5Vdc corresponds to 0 to 100% output.: $Z_{in} = 100k\Omega$ , current: $Z_{in} > 47k\Omega$ .
Voltage/current Load Regulation	$\pm 0.01\%$ ( no load to full load change).
Voltage/current line Regulation	$\pm 0.001\%$ (input Voltage line change $\pm 2\%$ ).
Operating Temperature	0 $^{\circ}C$ ~+50 $^{\circ}C$ . (-55 $^{\circ}C$ ~+85 $^{\circ}C$ can be customized)
Storage Temperature	-40 $^{\circ}C$ ~+85 $^{\circ}C$ .
Protection	Short circuit protection.
Humidity	0%~90% RH, non-condensing.
Cooling	30W units operating at full power might require additional cooling.
Dimensions	1.12" H x 1.5" W x 2.96" D (28.5mm x 38.1mm x 74.6mm).
Weight	150g

## PIN INFORMATION

### STANDARD

PIN	SIGNAL	PARAMETER
1	GND	Power Ground
2	+24Vdc	Power Input, standard +24Vdc $\pm 2\%$ option +12Vdc $\pm 2\%$ for 0~6W
3	Current Monitor	0~+5Vdc Output Current Monitor, $Z_{out}=1k\Omega$
4	HS	High start (ON=OPEN, OFF=GND)
5	VoltageMonitor	0~+5Vdc Output Current Monitor, $Z_{out}=1k\Omega$
6	GND	Signal Ground
7	IP-in	0~+5Vdc=0 to 100% rated output, $Z_{in}=100k\Omega$
8	VP-in	0~+5Vdc=0 to 100% rated output, $Z_{in}=100k\Omega$
9	+5Vdc	+5Vdc REF
10,11	GND	HV GND
12,13	HV	HV OUT

### M1 OPTION

PIN	SIGNAL	PARAMETER
1	GND	Power Ground
2	+24Vdc	Power Input, standard +24Vdc $\pm 2\%$ option +12Vdc $\pm 2\%$ for 0~6W
3	Current Monitor	0~+5Vdc Output Current Monitor, $Z_{out}=1k\Omega$
4	HS	High start (ON=OPEN, OFF=GND)
5	GND	Signal Ground
6	VP-in	P: 0~+5Vdc=100% rated output, $Z_{out}=100k\Omega$ N: +5Vdc~0=0 to 100% rated output, $Z_{out}=100k\Omega$
7	+5Vdc	+5Vdc REF
8	GND	HV GND
9	VoltageMonitor	0~+5Vdc Output Current Monitor, $Z_{out}=1k\Omega$
10,11	HV	HV OUT

### M2 OPTION

PIN	SIGNAL	PARAMETER
1	GND	Power Ground
2	GND	Power Ground
3	+24Vdc	Power Input, +24Vdc $\pm 2\%$ , option, +12Vdc $\pm 2\%$
4	+24Vdc	Power Input, +24Vdc $\pm 2\%$ , option, +12Vdc $\pm 2\%$
5	Current Monitor	0~+5Vdc Output Current Monitor, $Z_{out}=1k\Omega$
6	VoltageMonitor	0~+5Vdc Output Voltage Monitor, $Z_{out}=1k\Omega$
7	HS	High start (ON=OPEN, OFF=GND)
8	CC	Constant current
9	CV	Constant Voltage
10	GND	Signal Ground
11	IP-in	0~+5Vdc=0 to 100% rated output $Z_{in}=100k\Omega$
12	VP-in	0~+5Vdc=0 to 100% rated output $Z_{in}=100k\Omega$
13	+5Vdc	+5Vdc REF
14,15	HV GND	HV GND
16,17	HVOUT	HV OUT

### M3 OPTION

PIN	SIGNAL	PARAMETER
1	+24Vdc	Power Input, +24Vdc $\pm 2\%$ , option, +12Vdc $\pm 2\%$
2	GND	Power Ground
3	GND	Signal Ground
4	VP-in	0~+5Vdc=0 to 100% rated output $Z_{in}=100k\Omega$
5	+5Vdc	+5Vdc REF
6	HS	High start (ON=OPEN, OFF=GND)
7	Current Monitor	0~+5Vdc Output Current Monitor, $Z_{out}=1k\Omega$
8	VoltageMonitor	0~+5Vdc Output Voltage Monitor, $Z_{out}=1k\Omega$
9	GND	HV Ground
10	HV	HV OUT



**CONNECTION DIAGRAM**

**STANDARD**

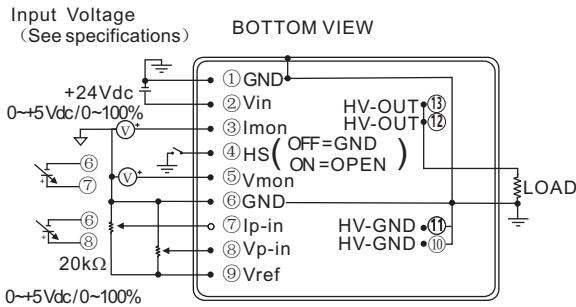

**M1 OPTION**

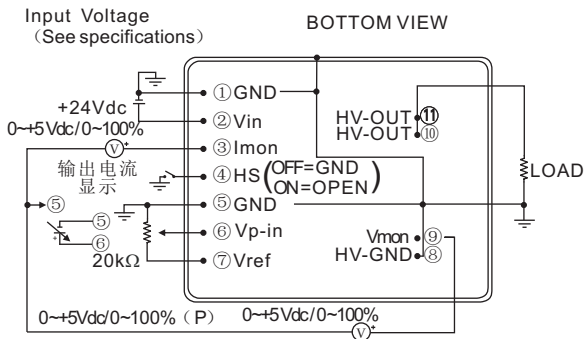

**M2 OPTION**

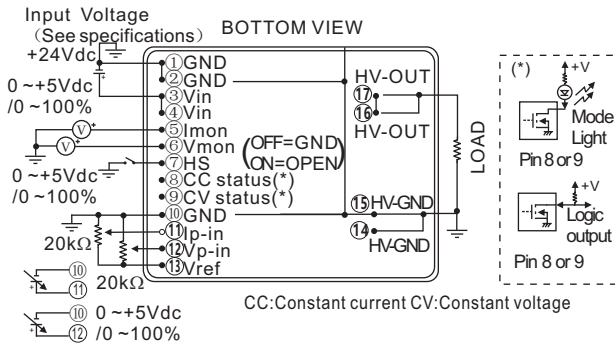

**M3 OPTION**

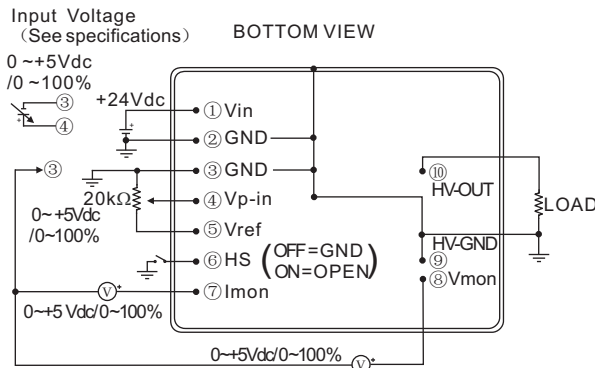

**DIMENSIONS: in. [mm]**

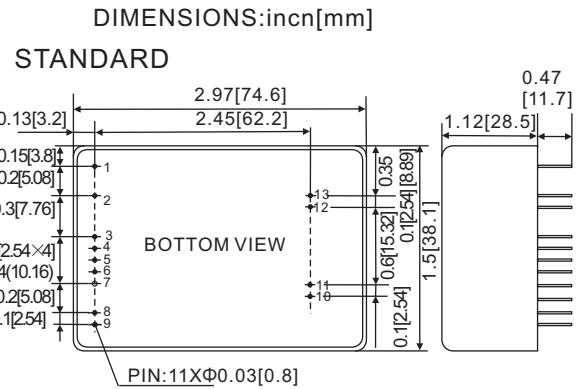

**M1 OPTION**

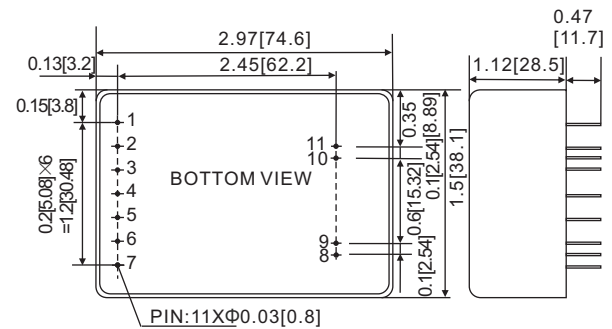

**M2 OPTION**

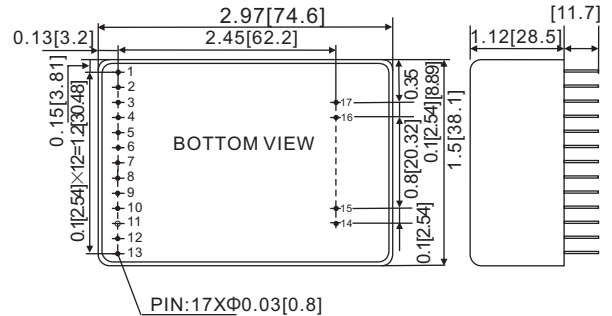

**M3 OPTION**

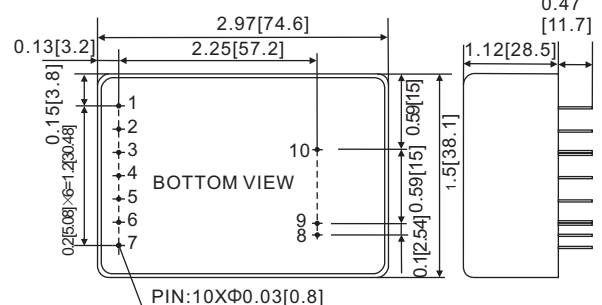

**A**  
**MICRO-MODULES**