



- EMBEDDED MICROCONTROLLER CONTROL
- AIR INSULATED
- LOW RIPPLE
- PULSE-WIDTH MODULATION
- INPUT VOLTAGE AVAILABLE
- TIGHT REGULATION
- VOLTAGE & CURRENT PROGRAMMING
- ARC AND SHORT CIRCUIT PROTECTED
- OEM CUSTOMIZATION AVAILABLE



G  
PAGODA

## INTRODUCTION

Wisman's open pagoda family are sophisticated 8 kW power supplies with extremely low ripple and noise. They are air insulated fast response units with tight regulation. This open stack series models consist of a rack style driver chassis, a high voltage stack assembly, and a remote control unit.

## TYPICAL APPLICATIONS

Accelerator, Capacitance characteristics, Electron beam, Ion beam, X-ray systems, Ion and chemical vapor deposition, Electrostatic precipitation. Science experiment, Industrial applications.

## TC SELECTION TABLE

kV	mA	P(kW)	MODEL	MAX STORED ENERGY(J)	HIGH FREQ. RIPPLE(P-P)	LINE FREQ. RIPPLE(P-P)
200	40.00	8.00	TC200*8	198	210V	20V
	80.00	16.00	TC200*16	396	210V	20V
250	32.00	8.00	TC250*8	232	220V	20V
	64.00	16.00	TC250*16	464	220V	20V
300	25.00	7.50	TC300*7.5	286	200V	20V
	50.00	15.00	TC300*15	572	200V	20V
350	18.00	6.30	TC350*6.3	321	175V	20V
	3600	12.60	TC350*12.6	642	175V	20V
400	14.00	5.60	TC400*5.6	375	155V	20V
	28.00	11.20	TC400*11.2	750	155V	20V
450	12.00	5.40	TC450*5.4	429	145V	20V
	24.00	10.80	TC450*10.8	858	145V	20V
500	10.00	5.00	TC500*5	464	140V	20V
	20.00	10.00	TC500*10	924	140V	20V
500-600		Pls contact Wisman's sales for the specific parameters				

## TC SELECTION EXAMPLE

TC	600	*	10	VIP	10	VIM	10	TR	SSX	ZS	3PH220	3PH380
Series Name	Max. Output Voltage (kV)	Output Polarity P: Positive Polarity N: Negative Polarity R: Polarity Reversible	Max. Output Power (kW)	OPTION VP: Voltage Programming IP: current programming VIP: Voltage and current programming	OPTION 10: 0~+10Vdc =0 to max. output 5 : 0~+5Vdc =0 to max. output	OPTION Vm: Voltage Monitor IM: current monitor VIM: Voltage and current monitor	OPTION 10: 0~+10Vdc =0 to max. output 5 : 0~+5Vdc =0 to max. output	OPTION ET: Ethernet TR: RS-232 AB: RS-485	OPTION Customized slow start X=5s, 15s, 20s or 30s, ±2.0%	OPTION Zero start INTLK	OPTION 180~220 VRMS, 3 φ input,	OPTION 342~420 VRMS, 3 φ input,



## SPECIFICATIONS

PARAMETER	DESCRIBE
Input Voltage	187~228V RMS, 3 $\phi$ , 48~63Hz.
Output Voltage	200~600kV Maximum output Voltage option, 8kW power option.
Efficiency	Typically 80% at full load.
Stability	0.01% per hour after 1/2 hour warm-up, 0.05% per 8 hours.
Temperature Coefficient	25ppm / $^{\circ}$ C.
Ripple	See TC selection table
Voltage Monitor	0~+10Vdcequivalentto0toratedvoltage.Zout=10k,WAccuracy: output change <0.2%, display change <0.5%.
Current Monitor	0~+10Vdcequivalentto0toratedcurrent.Zout=10kW,Accuracy: Output change <0.1%, display change <1%.
Voltage Local Programming	Internal potentiometer to set voltage from 0 to maximum output voltage.
Voltage Remote Programming	0~+10Vdc proportional from 0 to maximum output voltage.
Current Local Programming	Internal potentiometer to set current from 0 to maximum output current.
Current Remote Programming	0~+10Vdc proportional from 0 to maximum output current
Voltage Load Regulation	0.005% ( no load to full load change).
Voltage Line Regulation	$\pm$ 0.005% (input Voltage line change $\pm$ 2%).
Current Load Regulation	0.1% ( no load to full load change).
Current Line Regulation	$\pm$ 0.005% (input Voltage line change $\pm$ 2%).
Operating Temperature	-20 $^{\circ}$ C~+40 $^{\circ}$ C.
Storage Temperature	-40 $^{\circ}$ C~+85 $^{\circ}$ C.
Dimensions	driver chassis:8.43"H X 20.31" W X 22.56"D (214.1mm X 515.9mm X573.0mm).
	remote control unit:5.218"H X 19.00" W X 5.16"D (132.54mm X 482.6mm X130mm).

## RS-232/RS-485 DIGITAL INTERFACE <sup>D</sup>

JB3	SIGNAL	JB3	SIGNAL
1	N/C	6	N/C
2	TXD/Transmit Data	7	RS485B(OPTION)
3	RXD/Receive Data	8	N/C
4	N/C	9	RS485A(OPTION)
5	SGND		

## ETHERNET DIGITAL INTERFACE <sup>D</sup>

JB2	SIGNAL	JB2	SIGNAL
1	RX+	5	N/C
2	RX-	6	TX-
3	TX+	7	N/C
4	N/C	8	N/C



**TC ANALOG INFORMATION**

JB1	SIGNAL	PARAMETER
1	Power Supply Common	Power Supply Ground
2	Reset/HV Inhibit	Normally open, Low = Reset/Inhibit
3	External Interlock	+24Vdc @ open, <25mA @ closed
4	External Interlock Return	Return for External Interlock
5	mA Test Point	0~10Vdc=0~100% rated output, Zout=10kΩ
6	kV Test Point	0~10Vdc=0~100% rated output, Zout=10kΩ
7	+10Vdc Reference Output	+10Vdc @ 1mA
8	mA Program Input	0~10Vdc = 0~100% rated output, Zin=10MΩ
9	Local mA Program Output	0~10Vdc = 0~100% rated output, front panel pot
10	kV Program Input	0~10Vdc = 0~100% rated output, Zin=10MΩ
11	Local kV Program Output	0~10Vdc = 0~100% rated output, front panel pot
12	Remote Power On Output	+24Vdc @ open, <25mA @ closed
13	Remote Power On Return	Return for Remote Power On
14	Remote HV Off	+15Vdc @ open, <25mA @ closed, connect to pin15 for front panel operation
15	Remote HV Off/On Common	HV On/Off Common
16	Remote HV On	+15Vdc @ open, <25mA @ closed, connect to pin15 for front panel operation
17	HV Off Indicator	Low = HV Off
18	HV On Indicator	Low = HV On
19	Power Supply Common	Supply Ground
20	+24Vdc Output	+24Vdc @ 100mA, maximum
21	Voltage Mode Status	Open Collector, Low = Active
22	Current Mode Status	Open Collector, Low = Active
23	Power Mode Status	Open Collector, Low = Active(Option)
24	Interlock Closed Status	Open Collector, Low = Active
25	Spare	Spare
26	Spare	Spare
27	Spare	Spare
28	Spare	Spare
29	Over Power Fault	Open Collector, Low = Active
30	Over Voltage Fault	Open Collector, Low = Active
31	Over Current Fault	Open Collector, Low = Active
32	System Fault	Open Collector, Low = Active
33	RGLT Error Fault	Open Collector, Low = Active
34	Arc	Open Collector, Low = Active
35	Over Temp Fault	Open Collector, Low = Active
36	AC Fault	Open Collector, Low = Active
37	Interlock	connect to pin19 for Interlock closed
38	Spare	Spare
39	Spare	Spare
40	Pull Voltage	Option connect to pin 44 or pin 45
41	Spare	Spare
42	Spare	Spare
43	Spare	Spare
44	+5Vdc Output	+5Vdc @ 100mA, maximum
45	+15Vdc Output	+15Vdc @ 100mA, maximum
46	-15Vdc Output	-15Vdc @ 10mA, maximum
47	Spare	Spare
48	Spare	Spare
49	Spare	Spare
50	Power Supply Common	Power Supply Ground

## TC DIMENSIONS

DIMENSIONS:in.[mm]

### HIGH VOLTAGE STACK AND DRIVE ASSEMBLY

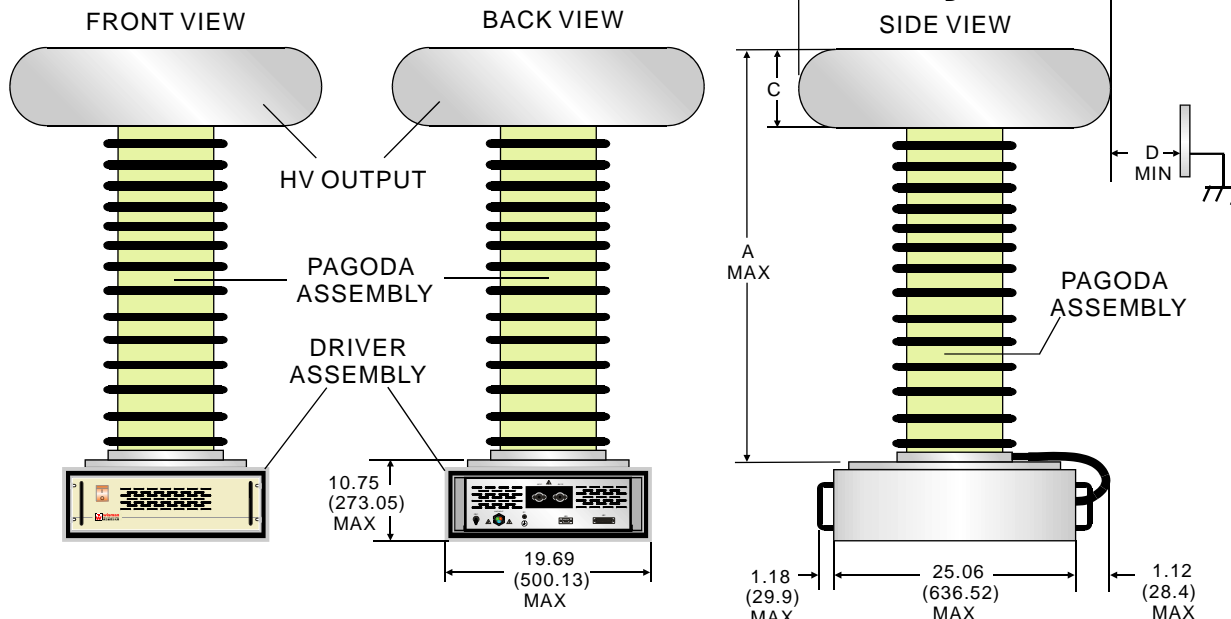

SIZE KV	A	B	C	D
200KV	30.00(762)	24(610)	5.00(127)	24(610)
250KV	37.30(947.42)	28(711)	7.00(178)	31(787)
300KV	41.50(1054.10)	28(711)	7.00(178)	38(965)
350KV	53.75(1365.25)	34(864)	8.50(216)	45(1143)
400KV	57.97(1472.44)	34(864)	8.50(216)	52(1321)
450KV	62.94(1598.67)	38(965)	10.00(254)	60(1524)
450KV	71.31(1711.27)	38(965)	10.00(254)	70(1778)
500~600KV	pls contact with the sales of Wisman for the specific parameters			

SIZE KV	E(the distance between two units in parallel)
200KV	6.81(172.97)
250KV	10.81(274.57)
300KV	10.81(274.57)
350KV	16.81(426.97)
400KV	16.81(426.97)
450KV	20.81(528.57)
500~600KV	pls contact with the sales of Wisman for the specific parameters

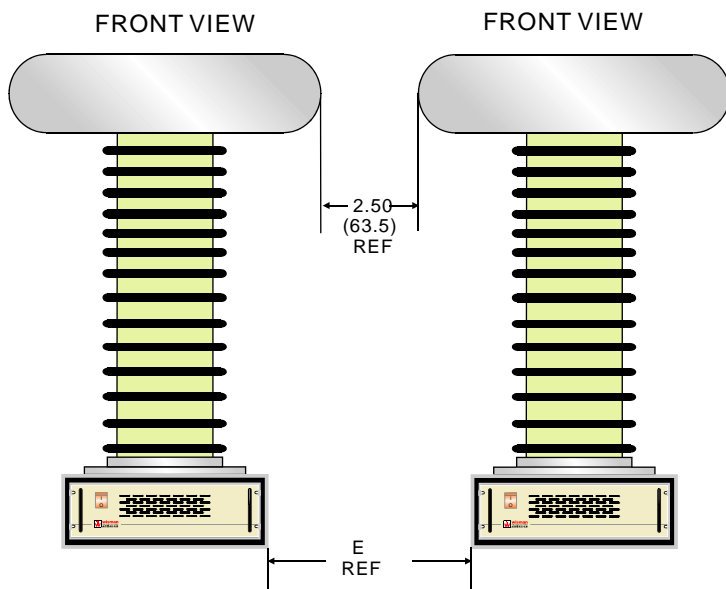

### CONTROL ASSEMBLY

